

# Liner Banded Liner System

Bi-Directional Banding Providing OSHA-Compliant Leading-Edge Fall Protection

## Roof Installation Instructions

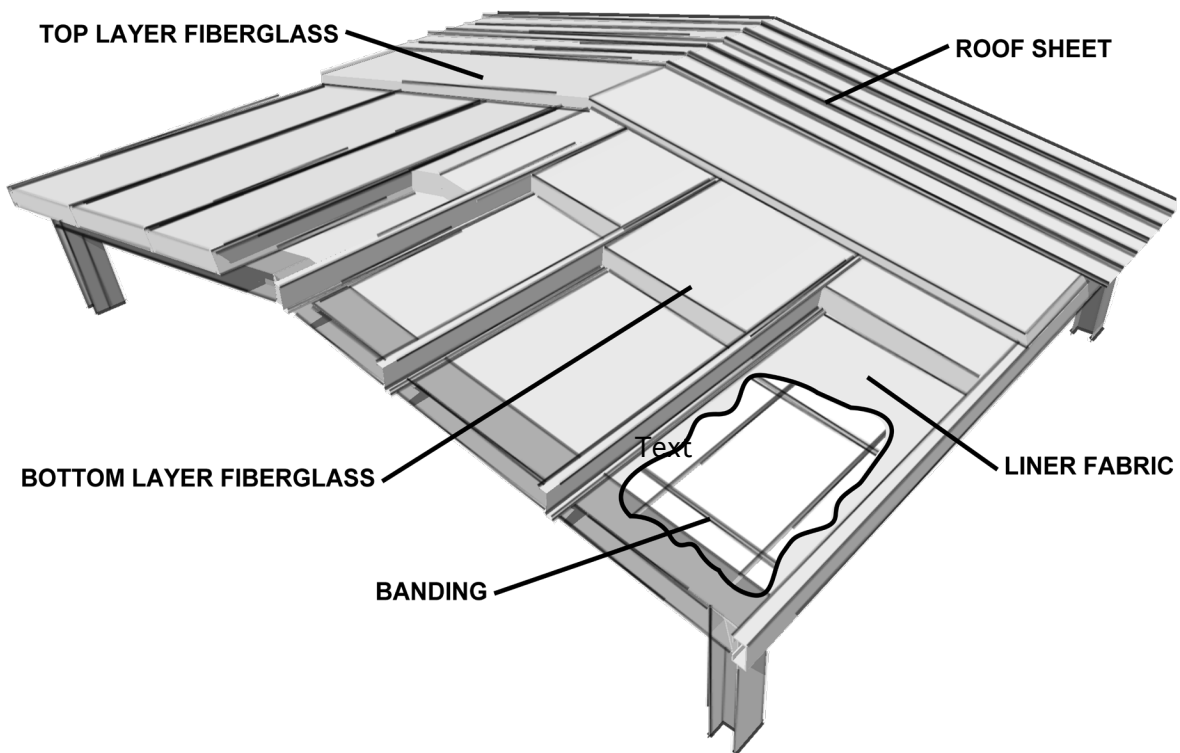

### Introduction

The Liner Bi-Directional Banded Liner System provides OSHA-compliant leading-edge fall protection while maximizing thermal performance in pre-engineered metal buildings using NAIMA 202-96 Owens Corning fiberglass. In addition to offering leading-edge fall protection, our Liner meets energy code requirements, improves the acoustical environment and aids in sound abatement, and provides a brighter finished interior.

# Liner Banded Liner System

Bi-Directional Banding Providing OSHA-Compliant Leading-Edge Fall Protection

## Roof Installation Instructions

### General

#### Safety Considerations

When installed in strict compliance with the following Bi-Directional Banding instructions and by a “Competent Person” as defined in OSHA Standard 29 CFR 1926.751, our Liner meets the requirements of OSHA Standard 29 CFR 1926.502 (c)(4)(i) and OSHA Standard 29 CFR 1926.760 (a)(1) for leading edge fall protection and OSHA Standard 29 CFR 1926.754 (e)(3)(i) covers for roof and floor openings. Any deviation from these installation instructions or substitution of any original components will nullify compliance with these OSHA standards.

Other means of fall protection, such as perimeter safety or guide lines, must be used at all times during the installation of the support banding and prior to the completed placement of the liner support fabric. The use of ProLiner™ is only one part of the overall site-specific safety plan for the construction site.

**Caution - Required Personal Protective Equipment: Safety glasses, cut-proof gloves (for sharp banding edges), long sleeve/loose fitting clothing (for insulation installation).**

#### Before You Start

- Open pallets and packaging to ensure complete order was received. Therm-All nor the carrier are responsible for missing or shorted materials if not noted on the carrier’s bill of lading upon delivery.
- Review shop drawings to ensure each custom-made fabric panel is installed in the appropriate area.
- Obtain necessary rake/base angles for your building type for fabric and banding attachment.
- Optional lightweight steel angle for ProLiner™ roof to wall fabric transition is recommended (see shop drawings for detailing).
- Assemble appropriate equipment and tools.
- Assure weather is appropriate to begin installation. Never install fabric panels in a bay that can’t be covered by day’s end.

#### Materials List

- 1” banding (and dispenser)
- Fabric panels
- TEK fasteners
- Adhesive (and brushes) and/or double-sided tape
- Insulation per specification
- Patch tape if required

#### Equipment and Tools Required

- Man lift/scissor lift/fall protection harness and lanyards
- Screw guns with 5/16” nut setters
- Tape measures
- Razor knives
- Metal tin snips
- Iron pipe for banding dispenser
- Safety glasses, cut-proof gloves and hard hat
- Locking c-clamps

# Liner Banded Liner System

Bi-Directional Banding Providing OSHA-Compliant Leading-Edge Fall Protection

## Roof Installation Instructions

### Installation

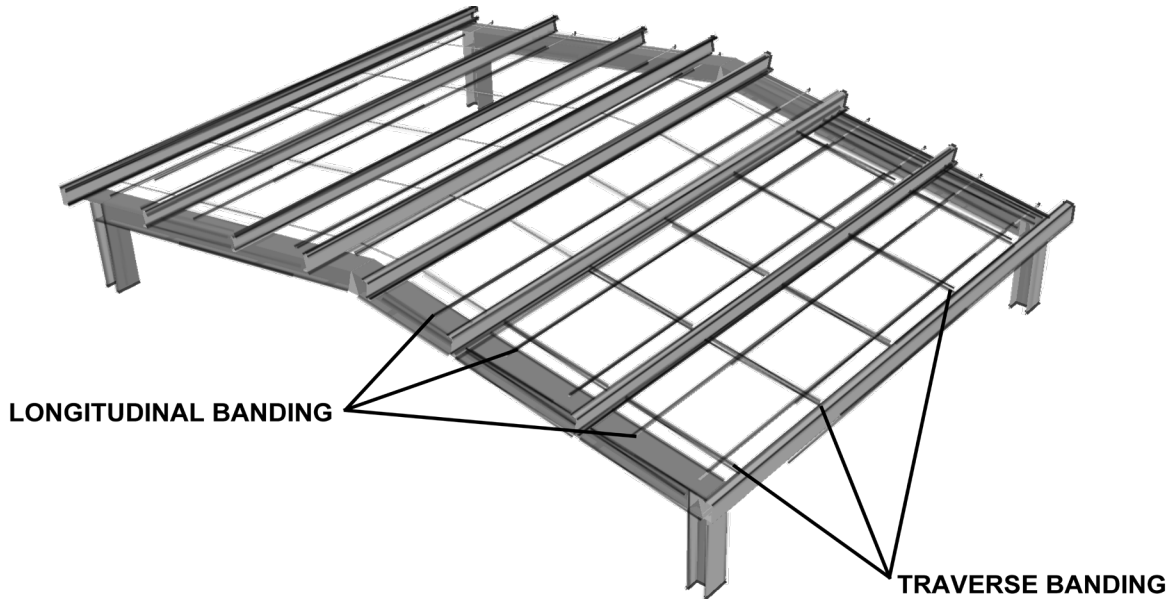

### Preparation:

#### A. Longitudinal Banding Parallel to the Purlins

1. Determine the number of 1" wide bands required based on the building size and design. This will include accounting for the following:
  - Two bands within the ridge and eave spaces regardless of width
  - Two bands for each purlin spacing that is 42" on center or greater
  - One band for each purlin space that is less than 42" on center

### DO NOT SPLICE PARALLEL BANDING

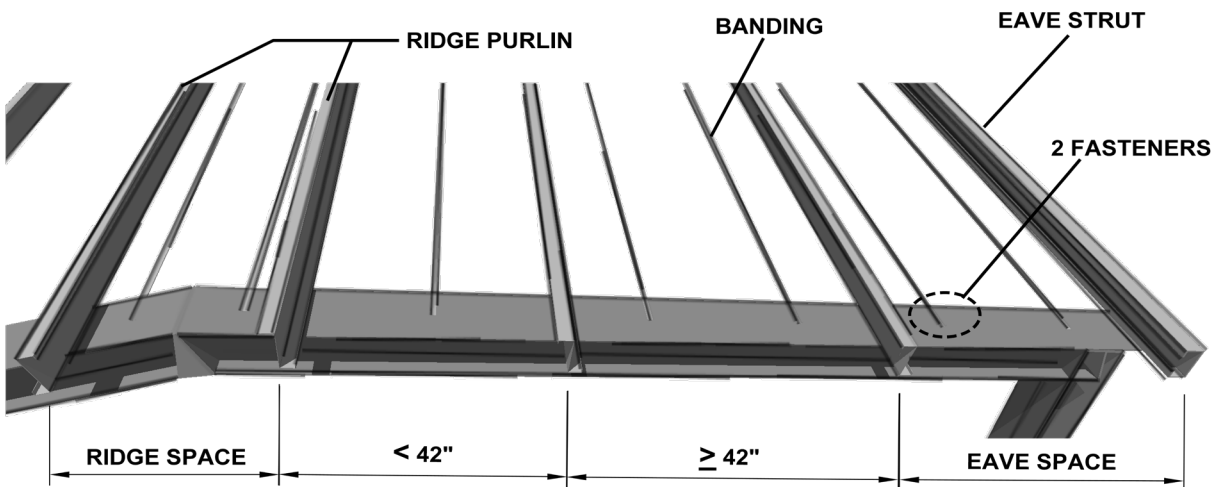

# Liner Banded Liner System

Bi-Directional Banding Providing OSHA-Compliant Leading-Edge Fall Protection

## Roof Installation Instructions

### Installation:

- Position each band off of the purlins equal to  $\frac{1}{4}$  of the purlin spacing for all spacing greater than 42". For spacings less than 42", divide the spacing in half.
- Set up coils of steel banding to dispense parallel to the purlins. Cut all bands to reach from endwall to endwall plus 2'0" for handling and fastening.
- Pull bands from endwall to endwall over each intermediate rafter and fasten to the far endwall rafter using two (2) of the 1- $\frac{1}{4}$ " TEK 5 fasteners provided, spaced 3" apart. Pre-drilling pilot holes in endwall rafters may ease installation. Pull banding hand-tight and fasten to the near endwall rafter in the same manner. Always make certain TEKS are centered when screwing into all roof banding.

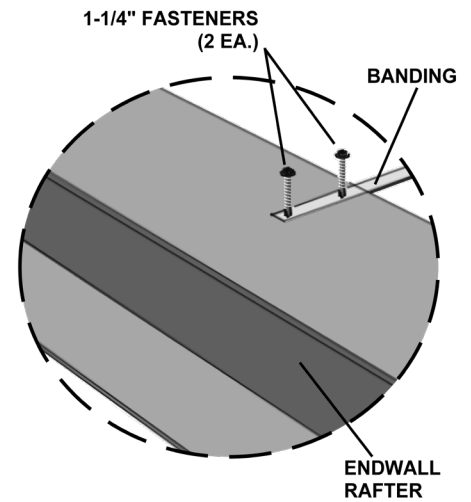

**DO NOT FASTEN PARALLEL BANDING INTO INTERMEDIATE RAFTERS.**

NOTE: If installing a ProLiner™ wall system with the ProLiner™ roof system, an additional longitudinal band can be installed within the eave space, plumb with the inner wall girt flanges, to support wall fabric at inner steel line. See shop drawings for optional steel angle use technique.

### B. Traverse Banding Perpendicular to Purlins

- Determine the width of the bay and refer to Table 1 for number of bands required. Divide the bay into equal increments for installing main area banding 60" on center or less. In addition, include one band 8" off each rafter flange edge.

NOTE: If installing ProLiner™ as a single direction (perpendicular to purlins only) application, refer to Table 2 for number of bands required for installing banding 48" on center or less.

**IMPORTANT – SINGLE DIRECTION LINER INSTALLATION DOES NOT OFFER OSHA-COMPLIANT LEADING-EDGE FALL PROTECTION.**

Table 1 (60" Spacing)

Bay Width (Feet)	# Bands For Main Area	# Bands 8" From Rafter Flange	Total # Of Bands For Bay
6-10	1	2	3
11-15	2	2	4
16-20	3	2	5
21-25	4	2	6
26-30	5	2	7
31-35	6	2	8
36-40	7	2	9
41-45	8	2	10

Table 2 (48" Spacing)

Bay Width (Feet)	# Bands For Main Area	# Bands 8" From Rafter Flange	Total # Of Bands For Bay
9-12	2	2	4
13-16	3	2	5
17-20	4	2	6
21-24	5	2	7
25-28	6	2	8
29-32	7	2	9
33-36	8	2	10
37-40	9	2	11
41-44	10	2	12

# Liner Banded Liner System

Bi-Directional Banding Providing OSHA-Compliant Leading-Edge Fall Protection

## Roof Installation Instructions

2. Set up rolls of steel banding to dispense perpendicular to the purlins. Cut all bands to reach from sidewall to sidewall (accounting for roof pitch) plus 2'0" for handling and fastening.
3. Fasten one end of each traverse band to the bottom of the sidewall eave strut using one (1) of the  $\frac{3}{4}$ " TEK 3 fasteners with washers provided. Allow for 3" of excess banding to hang outward past the fastener.

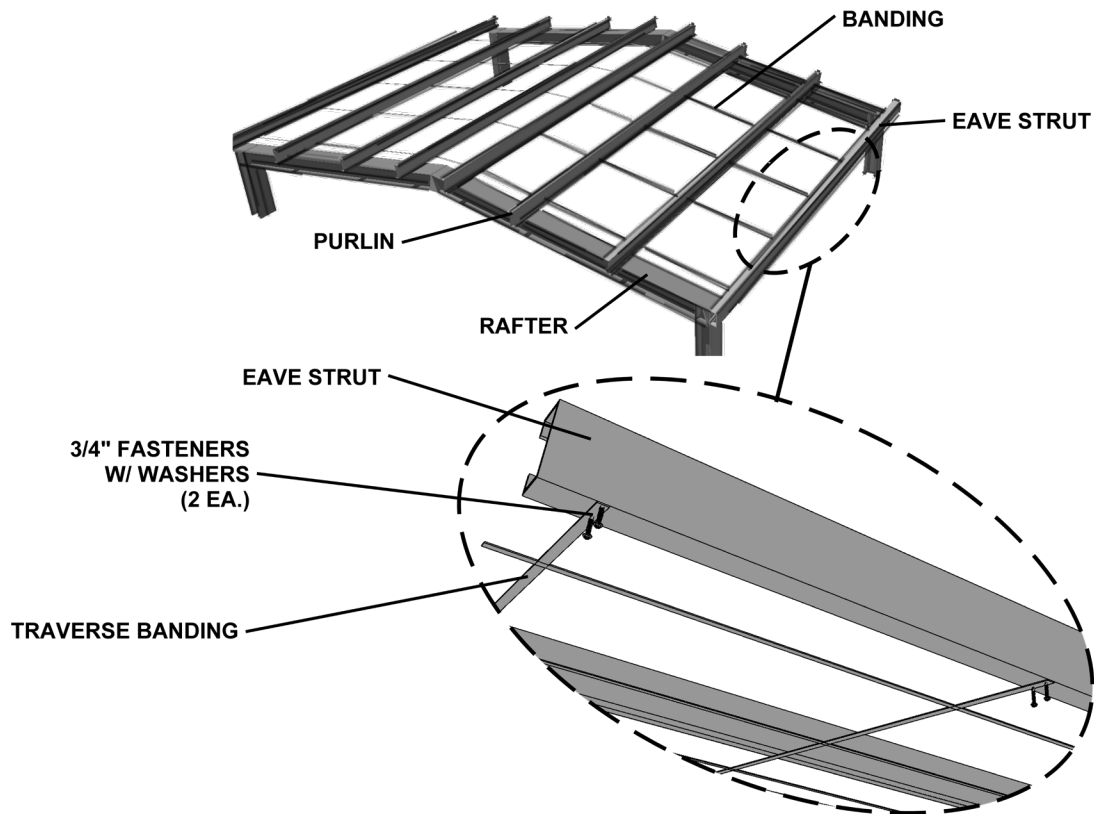

4. Pull each band hand-tight towards the ridge purlins while weaving above every 7<sup>th</sup> or 8<sup>th</sup> longitudinal band and above the bands in the ridge space. Fasten to the ridge purlins and far eave strut using one (1) of the  $\frac{3}{4}$ " TEK 3 fasteners with washers provided. **Do not fasten into purlins at this point.**

# Liner Banded Liner System

Bi-Directional Banding Providing OSHA-Compliant Leading-Edge Fall Protection

## Roof Installation Instructions

### C. Fabric Installation

1. Select the custom-sized fabric panel designated for the bay in which you are working per supplied drawings and unroll the fabric bundle across the top of the ridge purlin(s).
2. Place the fabric on the two (2) longitudinal steel bands in the ridge space. Remove the  $\frac{3}{4}$ " TEK 3 fastener with washers from the traverse banding at the ridge purlin nearest the side of the roof you intend to install first.

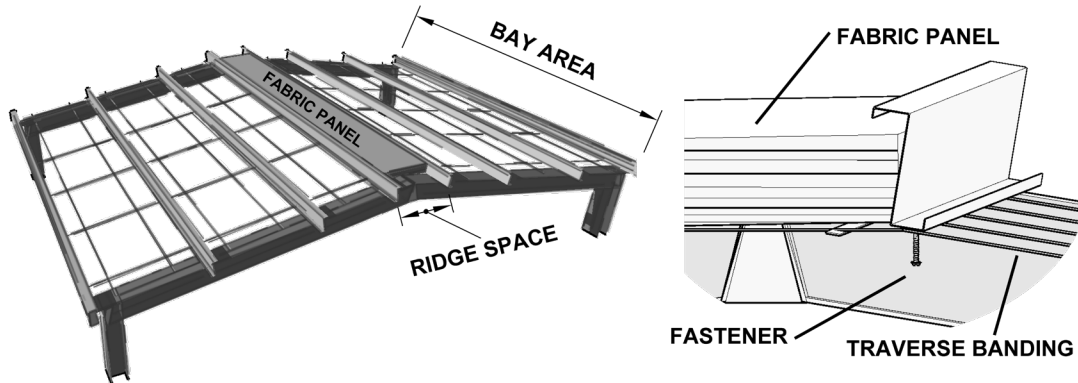

3. Pull one edge of the fabric under the purlins and on top of the banding while making sure the finished side (usually white) faces down toward the building's interior. Complete one half of the bay at a time. For easiest deployment, it is recommended that two (2) workers at each edge of the fabric bundle place a 1'0" upward and inward folded tab on both edges nearest the rafters as the fabric is deployed so that the edges won't hang up at the purlin/rafter connection point.

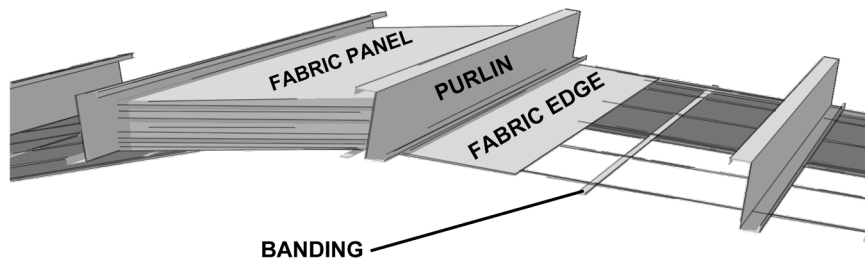

4. Continue pulling the fabric to the eave strut, squaring with rafters and eave while pulling equal size tabs tight to the frame's edge. Clamp the fabric at the outer corners of the bay at the eave strut and rafter intersection leaving enough fabric to cover the underside of the eave strut.
5. Remove eave fastener, apply adhesive or double-sided tape to underside of eave, reapply fabric to eave and reattach banding and  $\frac{3}{4}$ " TEK 3 fasteners with washers in the original holes where previously located. Install a second  $\frac{3}{4}$ " TEK 3 fastener with washer through the fabric/banding and into the eave strut during this step.

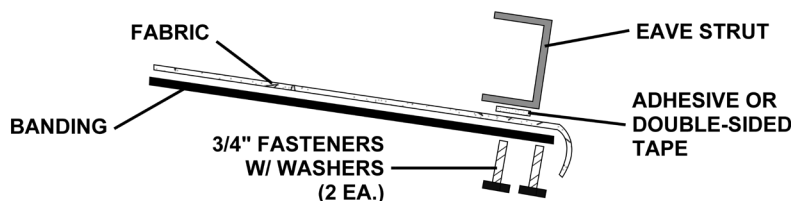

# Liner Banded Liner System

Bi-Directional Banding Providing OSHA-Compliant Leading-Edge Fall Protection

## Roof Installation Instructions

6. Work fabric from the eave strut, smoothing the fabric in each purlin space, back to the ridge. Cut around any penetrations and ensure proper seal with provided patch tape once installation is complete.
7. Notch the upward folded fabric edge to fit neatly around each purlin at the rafter as two (2) rooftop workers on opposing sides of the bay work together to pull and smooth the fabric tight across the bay length (rafter to rafter direction). During this process, using the provided adhesive or double-sided tape, attach the fabric to the tops of the rafters.
8. Using provided  $\frac{3}{4}$ " TEK 3 fasteners with washers, secure cross bands and fabric to bottom of intersected purlins working from eave to ridge. Re-attach ridge purlin fasteners.
9. When ready to dispense fabric on opposite slope, flip fabric bundle over to allow it to deploy from top of the bundle and repeat previous steps. Remember to add a second  $\frac{3}{4}$ " TEK 3 fastener with washer into the far eave strut and allow for 3" of excess banding to hang outward past the fasteners.

**Note:** Some bay spaces may be too wide for a single fabric panel to cover. If this occurs, see shop drawings for banding and fabric splicing detail.

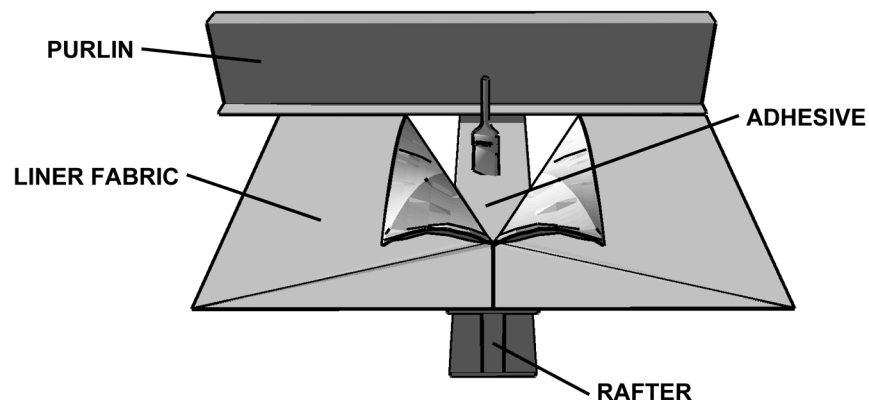
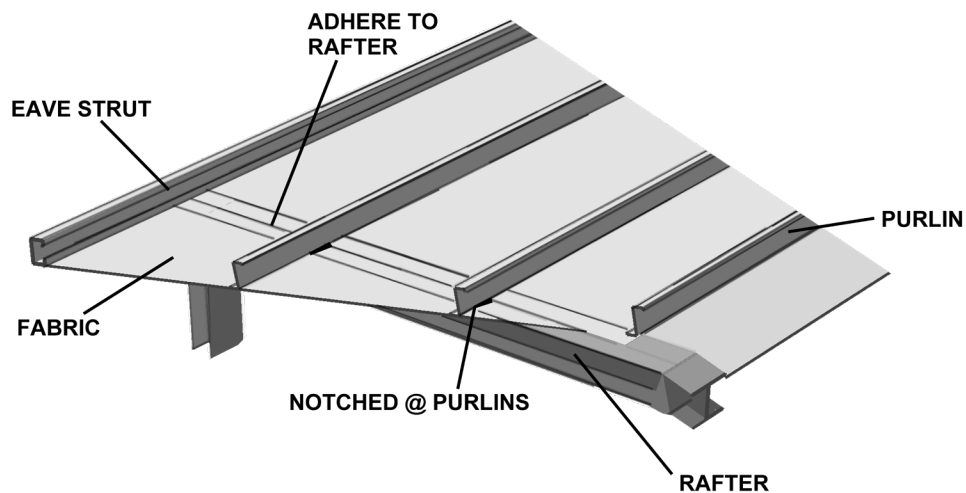

# Liner Banded Liner System

Bi-Directional Banding Providing OSHA-Compliant Leading-Edge Fall Protection

## Roof Installation Instructions

### D. Insulation Installation

1. The first/lower layer of unfaced fiberglass insulation is rolled out between the purlins and is provided in custom-cut widths; however, some rolls may be supplied slightly wider for a snug fit. Refer to the Insulation Layout contained within the shop drawings to determine location. Completely filling the area between the liner fabric and outer metal roof panel with unfaced insulation will reduce the possibility of condensation.
2. To allow for purlin bridging/bracing enclosure and complete insulation recovery, cut around steel members and butt roll ends to eliminate gaps or voids.
3. Install the second/top layer of insulation perpendicular to and over the tops of the purlins. Butt roll ends to eliminate gaps or voids. Since unfaced is provided in factory lengths, eave cutoffs should be kept to start the next run as metal roof sheeting progresses.
4. Install thermal blocks if required per PEMB specifications or for energy code compliance and complete by installing specified metal roofing components.

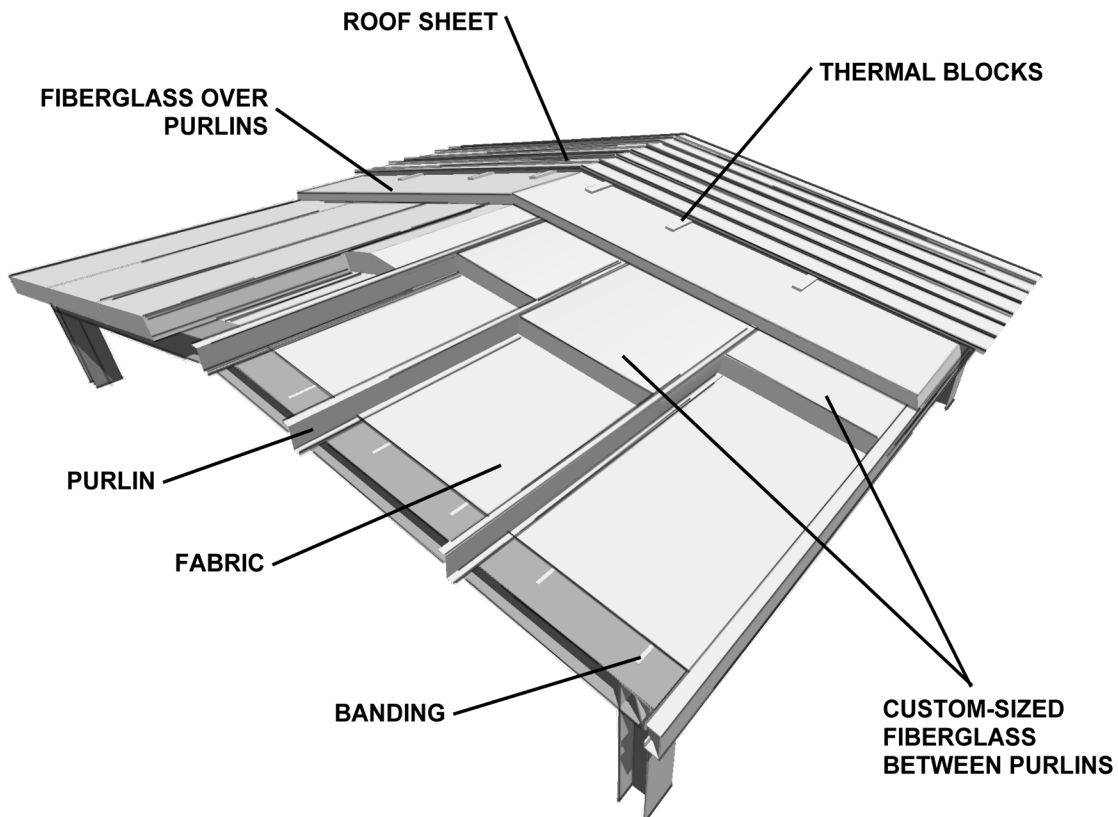



# Liner Banded Liner System

Bi-Directional Banding Providing OSHA-Compliant Leading-Edge Fall Protection

## Roof Installation Instructions

### E. Optional Brace Clip Installation

The use of brace clips and/or flush mount flanges may allow for mounting of knee bracing to the bottom of the purlins. This practice can improve the finished look of ProLiner™ by minimizing the number of cuts needed when installing the fabric liner. These clips and bracing shall only be used when approved in writing by the metal building manufacturer. Without approval, the liner fabric should be cut and sealed around all flange bracing using the supplied patch tape. Contact the metal building manufacturer for details on availability of brace clips or flush mount flange bracing.

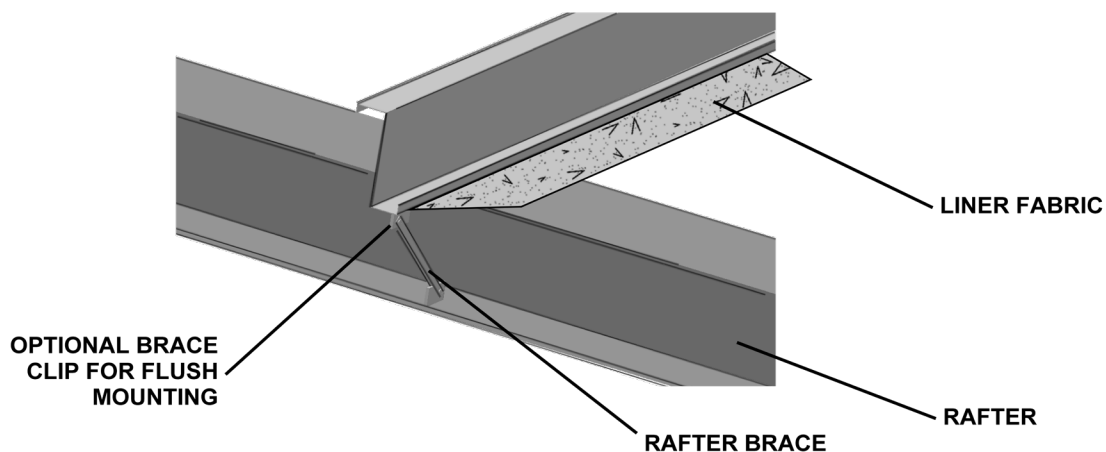

1. NOTE – Throughout the installation process, ensure all fabric edges are sealed properly to adjacent surfaces to maintain vapor and air barrier integrity.
2. NOTE – Fall protection is not provided within 6'0" of the roof edge or beyond the edge, within 6'0" of any common intermediate rafter where the system (fabric and banding) has not been installed in both bays, within 6'0" of either side of an intermediate rafter where a longitudinal band has been screwed into and within 6'0" of any rooftop opening.
3. NOTE – Our Liner is not intended for use in high humidity applications (consistent relative humidity levels greater than 30%) or structures housing open sources of water.
4. NOTE – Our Liner should never be stepped or walked on and is a single-use leading-edge fall protection liner system. Dispose of and replace all fabric/components if a fall should occur.
5. NOTE – Optional lightweight metal angle at eave and/or base (and required fasteners) is the responsibility of the installing contractor or metal building manufacturer.
6. NOTE – Please consult your metal building manufacturer to verify their recommended procedure for temporarily removing bracing components during the installation of the Liner Banded Liner System.